

# MCD

## Cabinet Centrifugal Inline Fan

**DLK**<sup>®</sup>  
VENTILATOREN

For applications where high air-flow and high static pressure ventilation is required. It is suitable for ceiling ventilation, ducted air conditioning and HVAC ventilation with 3-speed motor design.

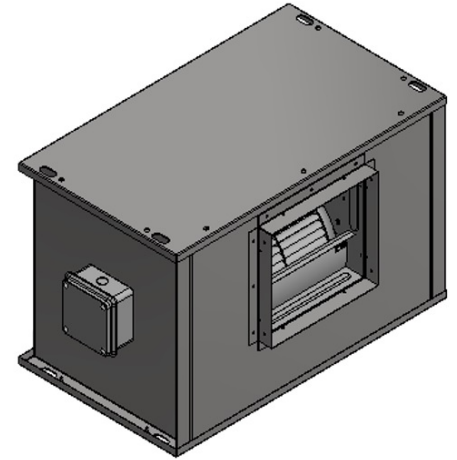

# TYPE MCD

## **APPLICATION**

DLK MCD series fans are suitable for ceiling ventilation, ducted air conditioning and HVAC ventilation. Widely used in office, shopping mall, hotel, hospital, restaurant and factory.

## **CONSTRUCTION**

Casing manufactured in galvanised steel complete with inlet and outlet spigots. Internal acoustics lining is available as option for better acoustics performance.

## **IMPELLER**

High efficiency, forward curved blades manufactured in galvanised steel plate.

## **MOTOR**

Built-in single phase 3-speed, internal rotor motor with IP20. Class B insulation, thermal overload protective device operate in 220V-1phase-50Hz.

# TECHNICAL DATA

Model	Motor Power	Speed	AirFlow (m³/h)	AirFlow (m³/h)	AirFlow (m³/h)	Volt.(V)	Nominal Amp.(A)	Cap. (µf/450V)	Dimension (mm)		
			150Pa	200Pa	300Pa				Height	Width	Length
MCD3 07/07 III	200W-4	H	1600	1300	NA	220-240	1.8	10	420	600	380
		M	1400	1100	NA						
		L	1200	900	NA						
MCD3 08/08 I	300W-4	H	2250	2130	1750	220-240	3.28	10	420	600	380
		M	1850	1750	1350						
		L	1600	1500	1100						
MCD3 09/07 I	375W-4	H	2050	2000	1950	220-240	4.2	10	450	700	400
		M	1530	1500	1450						
		L	1350	1300	1250						
MCD3 09/09 I	450W-4	H	2800	2900	2500	220-240	5.6	18	450	700	400
		M	1900	1800	1400						
		L	1400	1300	1100						
MCD3 10/08 I	550W-4	H	3200	3200	2900	220-240	4.9	18	500	750	450
		M	2200	2100	1900						
		L	1700	1600	1400						
MCD3 10/10 I	550W-4	H	3550	3400	3100	220-240	4.7	18	500	750	450
		M	2350	2300	1950						
		L	1900	1700	NA						
MCD3 12/09 I	750W-6	H	4300	3950	2900	220-240	5.4	18	580	850	550
		M	3100	2900	NA						
		L	2400	2250	NA						
MCD3 12/12 I	750W-6	H	4500	4500	3200	220-240	5.4	18	580	850	550
		M	3500	3200	NA						
		L	2750	2500	NA						

# Fan Dimensions

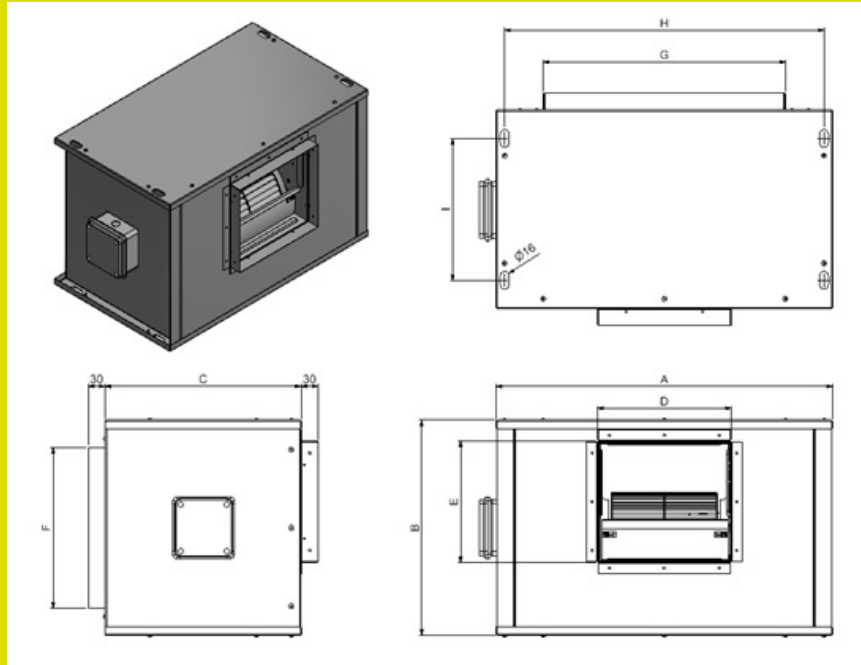

Model	Fan Size	A	B	C	D	E	F	G	H	I	Weight
MCD3-0707	0707 / 200W-4	600	420	380	238	214	282	432	570	250	18
MCD3-0808	0808 / 300W-4	600	420	380	291	260	322	682	820	290	26
MCD3-0907	0907 / 375W-4	700	450	400	236	266	350	544	700	300	34
MCD3-0909	0909 / 450W-4	700	450	400	302	266	350	644	800	300	36
MCD3-1008	1008 / 550W-4	750	500	450	269	292	400	544	700	350	41
MCD3-1010	1010 / 550W-4	750	500	450	335	292	400	644	800	350	44
MCD3-1209	1209 / 750W-6	850	580	550	313	345	482	762	900	450	50
MCD3-1212	1212 / 550W-6	850	580	550	399	345	482	762	900	450	52

# PERFORMANCE CURVE

## MCD3-0707

Fan Type: SYZ7-7 III Motor: 200W/4P Insulation protection: IP20  
 Volt: 220~240V Nom. Amps: 1.8A Insulation Class: B  
 Frequency: 50Hz Cap.: 10uf/450V

性能参数 Performance Parameter(1.2Kg/m<sup>3</sup>)

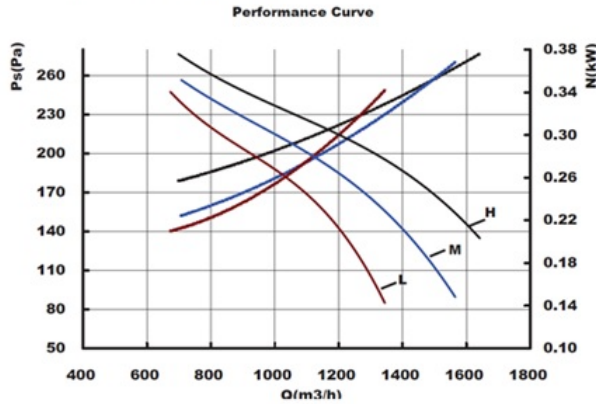

## MCD3-0808

Fan Type: SYZ8-88 I Motor: 300W/4P Insulation protection: IP20  
 Volt: 220~240V Nom. Amps: 3.3A Insulation Class: B  
 Frequency: 50Hz Cap.: 10uf/450V

性能参数 Performance Parameter(1.2Kg/m<sup>3</sup>)

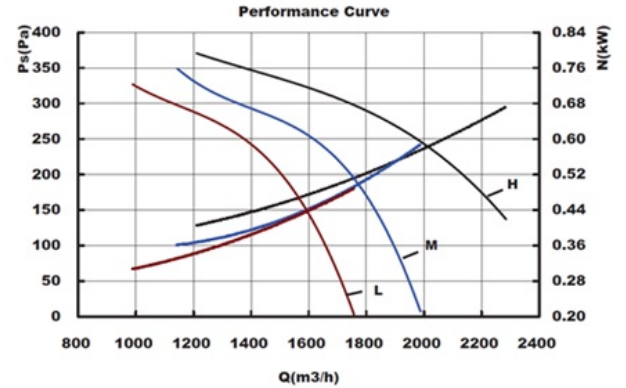

## MCD3-0907

Fan Type: SYZ9-7 III Motor: 375W/4P Insulation protection: IP20  
 Volt: 220~240V Nom. Amps: 4.2A Insulation Class: B  
 Frequency: 50Hz Cap.: 10uf/450V

性能参数 Performance Parameter(1.2Kg/m<sup>3</sup>)

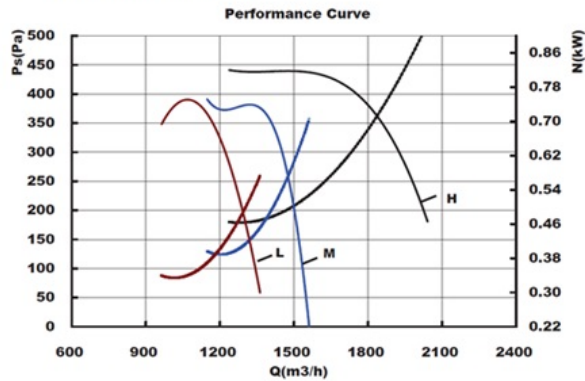

## MCD3-0909

Fan Type: SYZ9-9 I Motor: 450W/4P Insulation protection: IP20  
 Volt: 220~240V Nom. Amps: 5.6A Insulation Class: B  
 Frequency: 50Hz Cap.: 18uf/450V

性能参数 Performance Parameter(1.2Kg/m<sup>3</sup>)

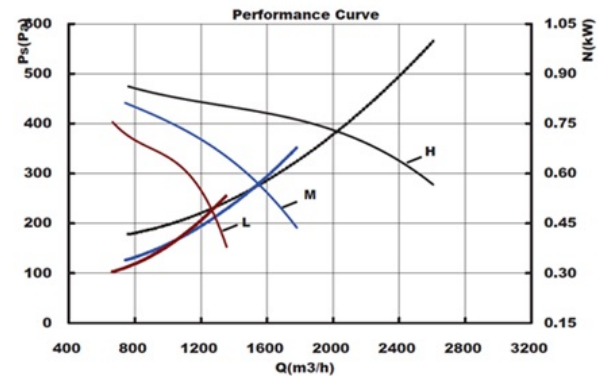

# PERFORMANCE CURVE

## MCD3-1008

Fan Type: SYZ10-8 I Motor: 550W/4P Insulation protection: IP20  
 Volt: 220~240V Nom. Amps: 4.9A Insulation Class: B  
 Frequency: 50Hz Cap.: 18uf/450V

性能参数 Performance Parameter(1.2Kg/m<sup>3</sup>)

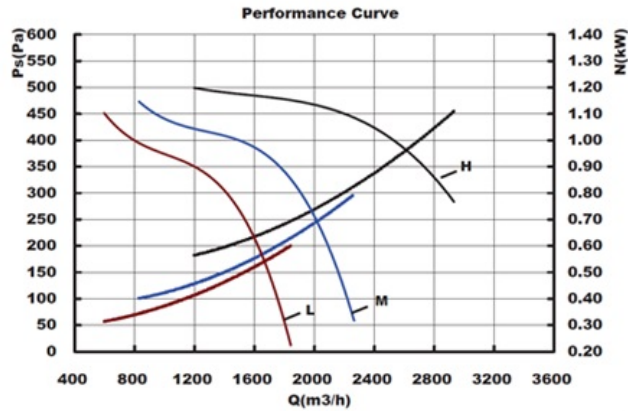

## MCD3-1010

Fan Type: SYZ10-10 I Motor: 550W/4P Insulation protection: IP20  
 Volt: 220~240V Nom. Amps: 4.9A Insulation Class: B  
 Frequency: 50Hz Cap.: 18uf/450V

性能参数 Performance Parameter(1.2Kg/m<sup>3</sup>)

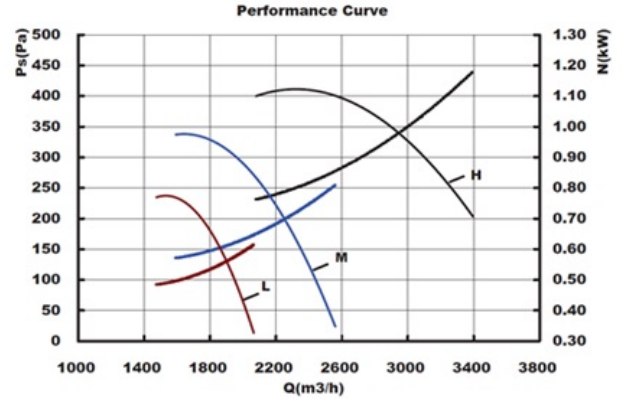

## MCD3-1209

Fan Type: SYZ12-9 I Motor: 750W/6P Insulation protection: IP20  
 Volt: 220~240V Nom. Amps: 5.4A Insulation Class: B  
 Frequency: 50Hz Cap.: 18uf/450V

性能参数 Performance Parameter(1.2Kg/m<sup>3</sup>)

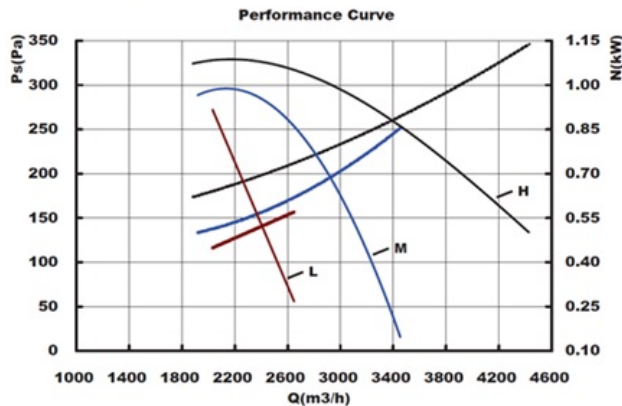

## MCD3-1212

Fan Type: SYZ12-12 I Motor: 750W/6P Insulation protection: IP20  
 Volt: 220~240V Nom. Amps: 5.4A Insulation Class: B  
 Frequency: 50Hz Cap.: 18uf/450V

性能参数 Performance Parameter(1.2Kg/m<sup>3</sup>)

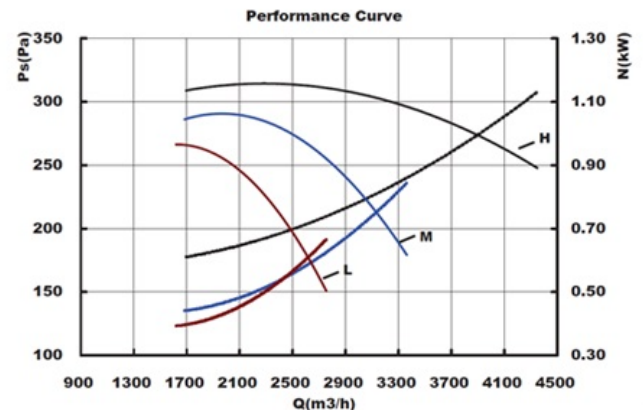

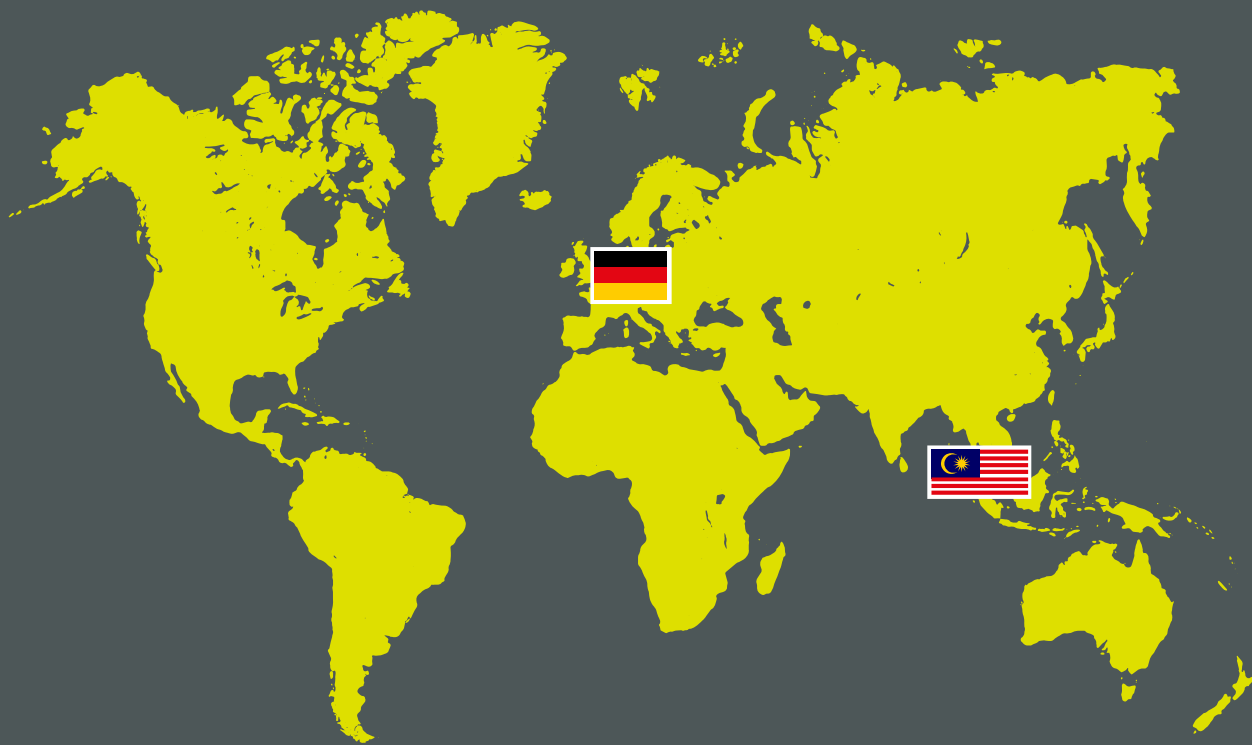

**DLK Ventilatoren GmbH**

Ziegeleistraße 18  
D-74214 Schöntal-Berlichingen  
Germany

fon: +49(0) 7943 – 9102 – 0  
fax: +49(0) 7943 – 9102 – 10  
mail: [info@dlk.com](mailto:info@dlk.com)

**DLK Ventilatoren Sdn Bhd**

No 22, Jalan Mega 2/1  
Kawasan Perindustrian Mega 2  
43500 Semenyih  
Selangor, Malaysia

fon : +603 8725 0845  
mail: [sales.asia@dlk.com](mailto:sales.asia@dlk.com)

[WWW.DLK.COM](http://WWW.DLK.COM)